

**Please note: Images shown are low resolution.
A new PDF of this Product Ordering Guide will
be uploaded on BMWcenternet the last week in
July, with high resolution images to be included.**

The essence of refined ferocity

Product Ordering Guide

Confidential information for use
by authorized BMW centers.

The all-new 2006
BMW M5 Sedan

CN1015568



The Ultimate
Driving Machine®

V-10 powered cloud 9



As awesome as the previous BMW M5 sports sedan was, the all-new M5 is stunningly superior. Where its predecessor featured a V-8 engine producing 400 horsepower, the new M5's engine is the most powerful BMW powerplant yet: 10 cylinders producing 500 hp at 7750 rpm, with an 8250 rpm redline. Arguably the finest engine on the market today, it propels the M5 from 0-60 in 4.5 seconds.¹ Perhaps that's why it recently won the title of Engine of the Year 2005, awarded at the Engine Expo 2005 in Stuttgart, Germany. The completely redesigned M5 offers room for five in a sedan that is comfortable and elegant for everyday use, yet ready and willing to respond with seemingly endless, high-revving power. With its dynamic M suspension, aggressive styling, luxurious interior, and advanced safety features, the new M5 is a technological tour de force, the more-than-worthy inheritor of the BMW marque.

¹ BMW AG test results.

/// Track star in a business suit

As one of the most exhilarating sports sedans in the world, the new M5 provides exterior clues to the power that lurks inside. At first glance, its primal curb presence and dynamic proportions hint at its potential. The muscular front air dam with its huge air scoops make the M5 appear fierce, but their true purpose is to help the V-10 engine breathe more freely, and cool the massive 14.7-inch brakes. In fact, every element of the body has been crafted to eliminate wind resistance and glue the M5 to the road for maximum performance. Aerodynamically designed side mirrors are another M styling cue, as are the M5's distinctive, modified side gills and exclusive wheel design, instantly identifying the M5's athletic, sporty, dynamic contours.



/// Unbridled passion from every angle

Regardless of which angle it is viewed from, the new M5 seems to radiate energy and uniqueness. It is, in fact, BMW's most emphatic expression of M power, notable even in its redesigned rear apron. Here will be found the distinctive two-plus-two chrome exhaust tips, an unmistakable feature of all M vehicles. Also in evidence are the somewhat more prominent wheel wells, which make room for and call attention to the M5's serious, wide, track-gripping tires. The deeper wheel wells also house the M5's exclusive 19-inch wheels in the traditional and instantly recognizable M double-spoke design. Thanks to a rear diffuser and flaps to the left and right, the rear end now has an extremely muscular look, emphasizing the M5's inherent power and promise.

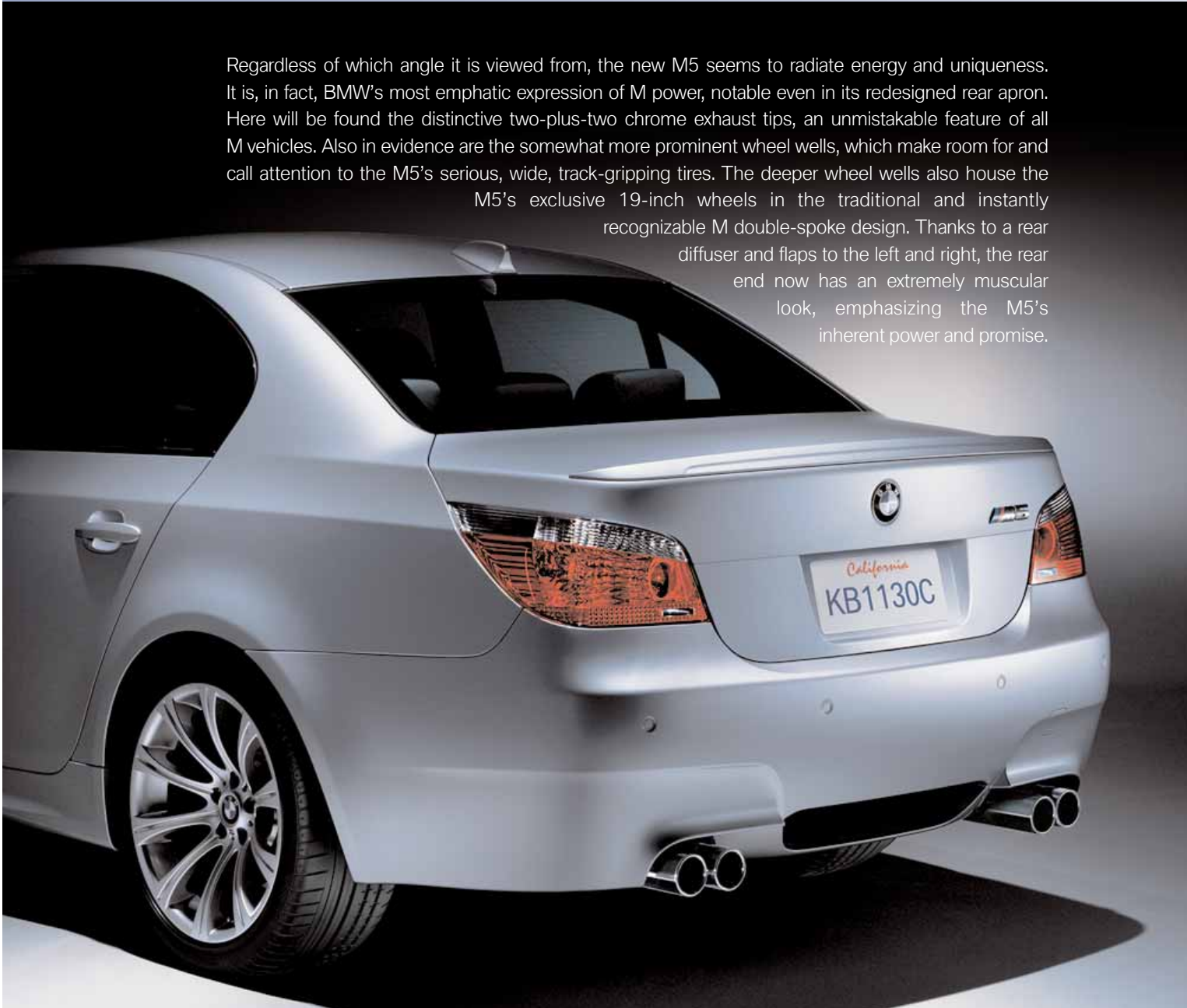

The driver's seat of the new M5 is refined and elegant, attired in supple Merino Leather with adjustable side bolsters. Aluminum-ringed gauges convey data quickly, and perfectly placed controls receive and execute commands instantly. The thick M multi-function steering wheel has essential functions placed exactly where a driver would instinctively reach for them. The new M5 offers an aggressive, very direct steering ratio of 12.4:1, a "must" for its high-speed driving potential. In short, the M5's cockpit embraces technology that adds to the fun of driving, but never intrudes upon it.



- Standard DVD-based navigation system with convenient Voice-Activation capability
- Optional Head-Up Display¹ projects important information directly onto the windshield
- Optional SIRIUS Satellite Radio
- iDrive system automatically remembers driver preferences in suspension setting – Comfort, Normal, and Sport – and Logic7 audio settings

¹Not available with Green band windshield.

/// Room for four envious passengers

The new M5 is the ultimate sports car doubling as a luxury sedan. An oversized moonroof lets in the sky. The cabin features climate control and highly supportive, bolstered M sport seats with adjustable thigh and lumbar support, covered in Merino Leather (see p.14 for available combinations of leather, trim, and seating). Three adults may sit in the rear cabin in comfort, with generous shoulder, leg, and headroom. Temperature and airflow can be adjusted independently of the front. And the entire cabin is filled with the superb sounds of the standard Logic7 audio system, which includes a 6-disc CD player in the glovebox and an additional player in the dash. In the new M5, driver and passengers alike travel in refined, sophisticated comfort.



Optional Features:

- Merino Leather upholstery (Full) interior covers the instrument panel, center console, and door panels with Merino Leather; Anthracite Alcantara covers the roofliner and side pillars
- Perforated Merino Leather upholstery (Full) includes Anthracite Alcantara roofliner and side pillars. Also includes Ventilated seat feature (requires optional M multi-function front seats)
- M multi-function front seats with active width adjustment
- Walnut Madeira or Olive Ash Wood trims available as no-cost options; Brushed Aluminum Shadow trim is standard
- 3-stage heated rear seats keep passengers comfortable in cool weather conditions
- Rear-window power roller sun blind and manual rear side-window sunshade screens keep glare out and promote visibility
- Rear side airbags further enhance passenger safety
- 60/40 split rear seating

///V-10: The power behind the legend

The new M5's equally new powerplant is, quite simply, the most potent production engine BMW has ever built. A 500 horsepower, 10-cylinder, high-revving, five-liter marvel, the engine produces 100 hp per liter, with a power-to-weight ratio of one horsepower per each eight lbs. It's virtually the same weight and displacement as its V-8 predecessor, yet generates 100 more horsepower for a 25% increase, with a redline of 8250 rpm and 383 lb-ft of maximum torque. A Power Button on the steering wheel lets the driver switch from a "default" engine output of 400 hp to the full, 500 hp, at will. 10 throttle butterflies (one per cylinder) keep the engine breathing freely at all times. In combination with Double-VANOS steplessly variable valve timing, the engine responds to commands instantaneously, and utilizes the world's most powerful engine control unit processor.

- **The first high-revving V-10 in a production sedan**
- **Awe-inspiring statistics:**
500 hp @ 7750 rpm
383 lb-ft of torque @ 6100 rpm, redline at 8250
0-60 mph in 4.5 seconds
- **A semi-dry-sump oil system keeps the M5 engine well lubricated**
- **Power button: default is 400 hp, pushing button allows use of entire 500 hp**

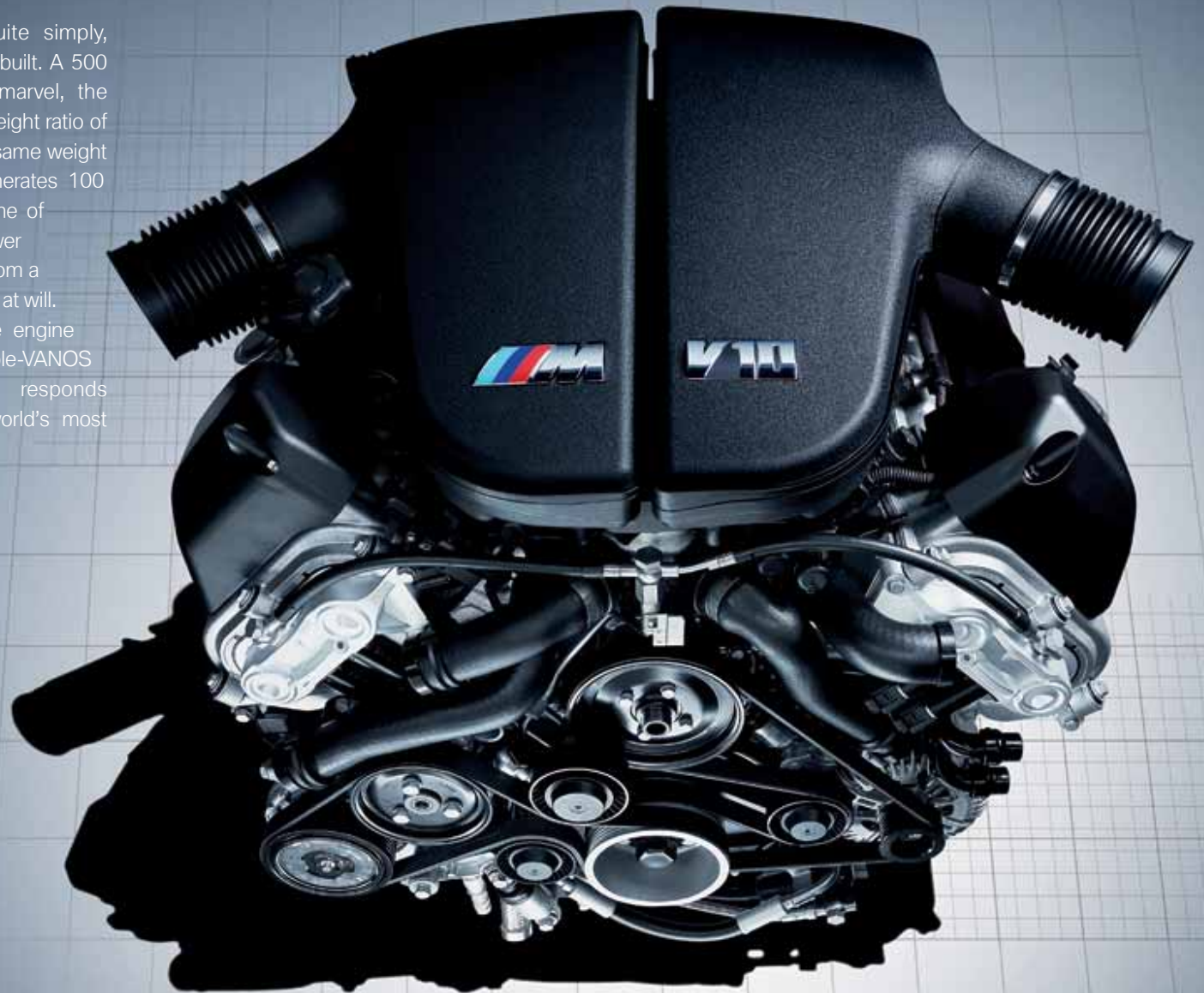

/// Seventh heaven for serious drivers

- Designed to handle a torque of up to 405.66 lb-ft
- SMG boosts shifting speed by 20%
- DRIVELOGIC offers 11 gear change options:
six manual (S mode), five automatic (A mode)

With an engine as high-revving as the new M5's, BMW needed to create an equally unique and capable transmission to take full advantage of it: the M5's advanced 7-speed SMG with DRIVELOGIC. The first 7-speed Sequential Manual Gearbox ever put into a production car, SMG lets the driver execute manual gear changes without a clutch pedal in as few as 80 milliseconds. With SMG's DRIVELOGIC function, drivers can choose from 11 gear change options, letting them adapt SMG's characteristics to their own motoring style, depending on road and weather conditions.

/// The drive of a lifetime

The new M5 features lightweight aluminum suspension and axles linked to powerful electronics, all designed to make the driving experience even more exhilarating. Electronic Damper Control (EDC) sets the suspension in any of three modes: Comfort, Normal, and Sport. Servotronic steering varies its level of assistance for direct, dynamic response at high speed (or in EDC Sport mode), while giving more assistance at low speeds. And the M Variable Differential Lock delivers more fun and power coming out of turns, while providing a sticky grip in slippery road conditions. Included in the M5's standard equipment are DSC and M Dynamic Mode, which let the driver push the car to its longitudinal and lateral acceleration limit, before DSC intervenes and helps bring the vehicle under control. All of which illustrates a primary BMW philosophy: "The suspension should always be faster than the engine."

- Well-balanced, nearly 50/50 weight distribution on front and rear axles
- Suspension features optimized DSC
- M Variable Differential Lock
- Forward progress maintained in any situation
- 100% locking power
- M Dynamic Mode offers awesome driving dynamics



The M5's 14.7-inch front/14.6-inch rear, weight-optimized, cross-drilled compound brakes:

- Outstanding braking characteristics in both wet and dry conditions, bringing the M5 to a complete stop from 60 mph in just 118 feet

/// Safety is the first rule of Motorsport



The BMW M5's Intelligent Safety and Information System (ISIS) employs 14 separate impact sensors, and one of the finest combinations of airbags and passive safety features available, for leading-edge protection. As soon as ISIS determines a severe accident is occurring, up to eight airbags are deployed throughout the cabin within a scant five-hundredths of a second. By employing an all-aluminum front end, rear end, and suspension, the M5's rigid body construction not only provides distinctively enhanced performance, but enhanced passive safety, as well. Proving that, even on a sports sedan as ferociously powerful as the M5, BMW's most important concern is always safety.



- Rigid body construction
- Drive shaft and axles made from aluminum, not traditional steel, for less weight, greater strength

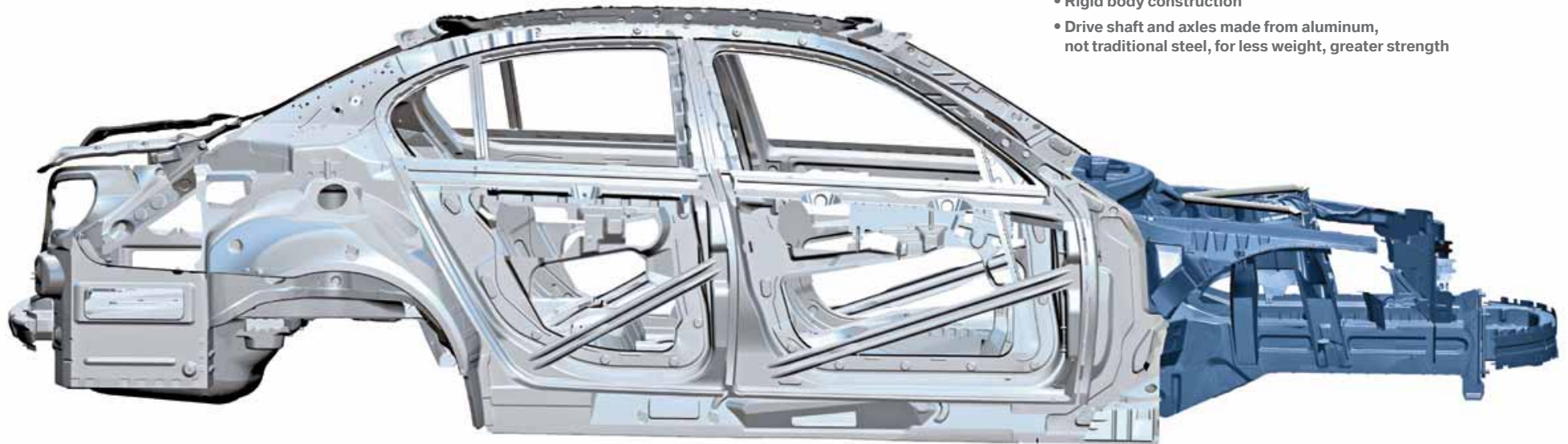

/// Exterior Colors

The sophisticated palette of exterior paint colors underscores the M5's elegant, understated looks. All colors are standard, including the four that are exclusive to the M5: Silverstone Silver Metallic, Sepang Bronze Metallic, Indianapolis Red Metallic, and Interlagos Blue Metallic.

Please note: Due to color printer capabilities, colors shown may not print out accurately.

Non-metallic

300	Alpine White	
-----	--------------	---

Metallic

A29	Silverstone Silver	
A08	Silver Gray	
A32	Sepang Bronze	
A31	Indianapolis Red	
A30	Interlagos Blue	
475	Black Sapphire	

Non-metallic

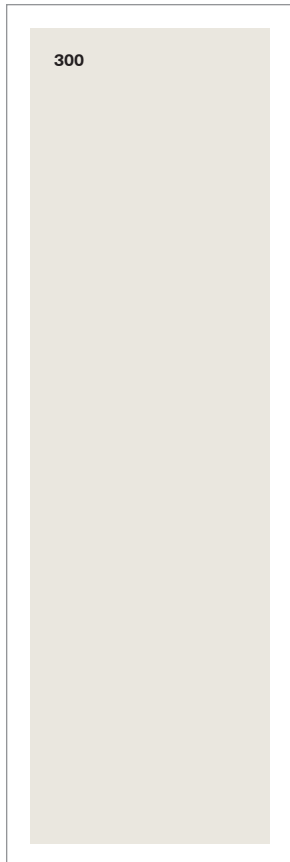

Metallic

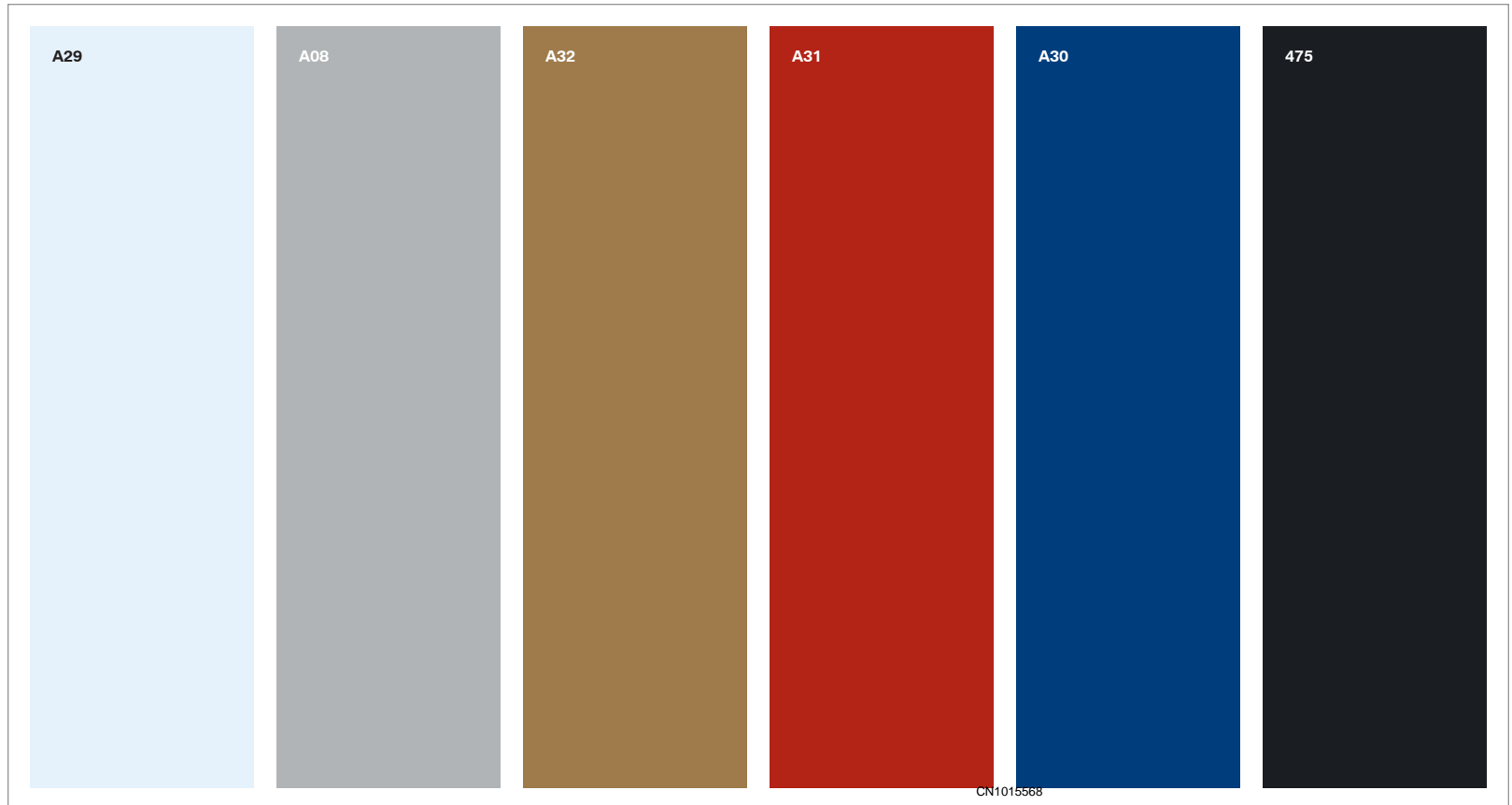

Interior Colors

The M5 interior comes standard with exclusive Merino Leather (Extended), which covers the seating area, gearshift knob and handbrake boots, and part of the dashboard. It also includes an Anthracite Cloth roofliner and side pillars.



Merino Leather (Extended)

LKA9	<input checked="" type="checkbox"/> Silverstone II	
LKA8	<input checked="" type="checkbox"/> Sepang	
LKSW	<input checked="" type="checkbox"/> Black	

The optional Perforated Merino Leather (Full) includes Anthracite Alcantara roofliner and side pillars. Also includes Ventilated seat feature (requires optional M multi-function front seats).

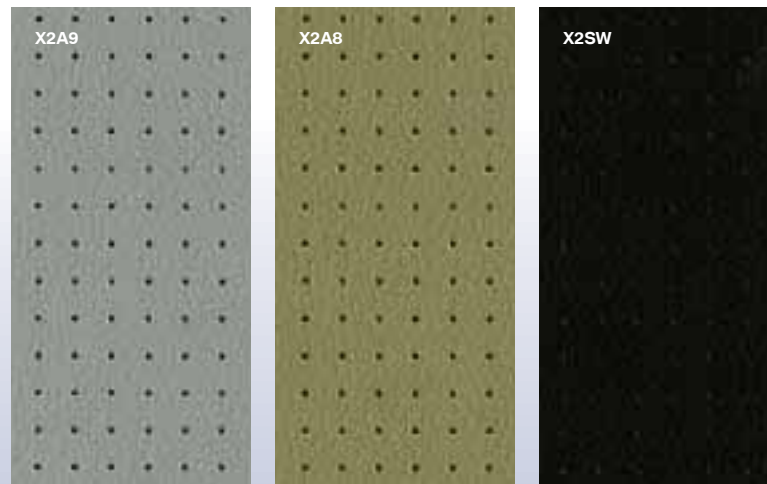

Perforated Merino Leather (Full)

X2A9	<input type="checkbox"/> Silverstone II	
X2A8	<input type="checkbox"/> Sepang	
X2SW	<input type="checkbox"/> Black	

With the optional Merino Leather (Full) interior, the dash, center console and door panels are all covered in rich leather. The roofliner is Anthracite Alcantara, a suede-like fabric that also covers the side pillars.

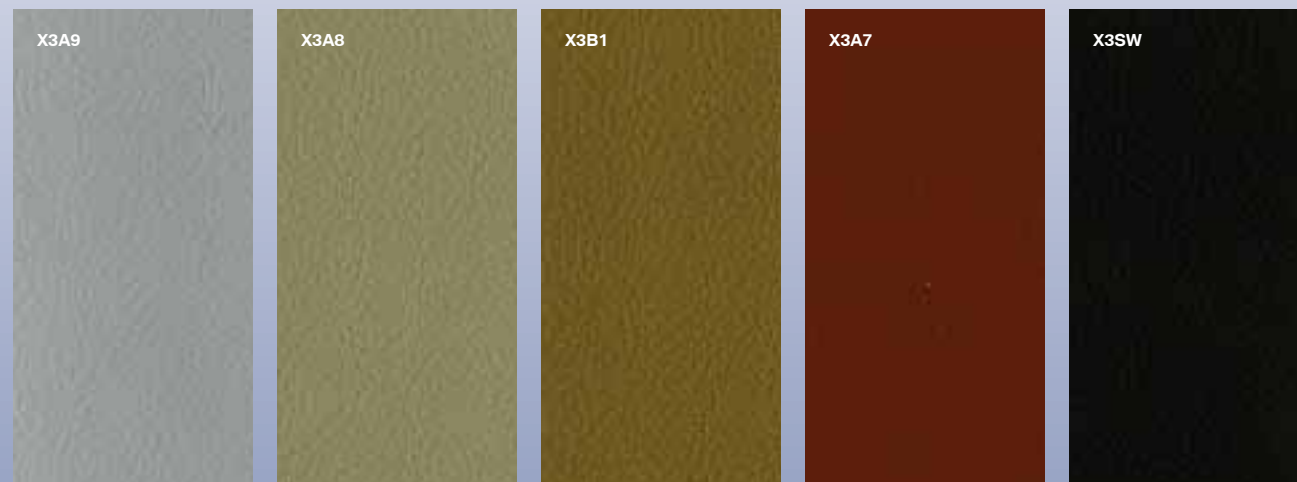

Merino Leather (Full)

X3A9	<input type="checkbox"/> Silverstone II	
X3A8	<input type="checkbox"/> Sepang	
X3B1	<input type="checkbox"/> Portland Brown	
X3A7	<input type="checkbox"/> Indianapolis Red	
X3SW	<input type="checkbox"/> Black	

Standard Optional

Please note: Due to color printer capabilities, colors shown may not print out accurately.

///Interior Trim

The M5 interior is highlighted by a choice of three handsome trims. Brushed Aluminum Shadow trim comes standard, enhancing the cabin's high-performance ambiance. For a more classic elegance, a choice of Olive Ash Wood or Walnut Madeira Wood trim are offered as no-cost options.

Please note: Due to color printer capabilities, colors shown may not print out accurately.

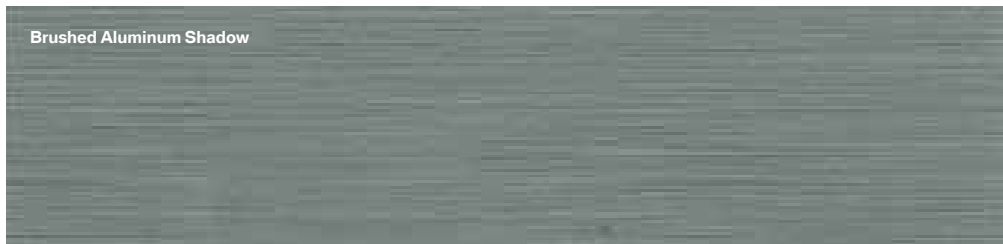

Brushed Aluminum Shadow

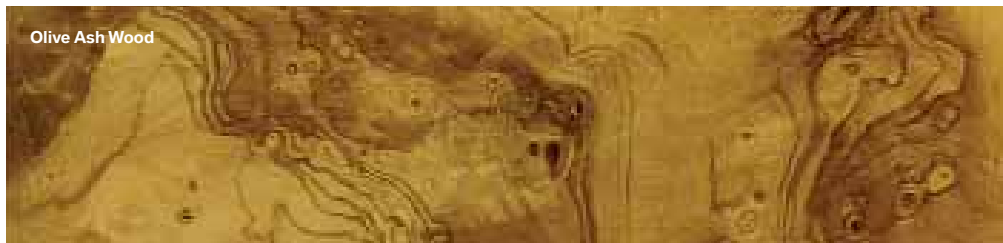

Olive Ash Wood



Walnut Madeira Wood

Interior trim

Brushed Aluminum Shadow

Olive Ash Wood

Walnut Madeira Wood

Standard No-cost option



/// Exterior and Interior Color Combinations

Upholstery colors	Merino Leather (Extended) ¹			Perforated Merino Leather (Full) ^{2,3}			Merino Leather (Full) ^{3,4}				
	Silverstone II	Sepang	Black	Silverstone II	Sepang	Black	Silverstone II	Sepang	Portland Brown	Indianapolis Red	Black
Exterior paint colors⁵											
300 Alpine White Non-metallic	●	●	●	●		●	●			●	●
A29 Silverstone Silver Metallic	●		●	●		●				●	●
A08 Silver Gray Metallic	●		●	●		●				●	●
A32 Sepang Bronze Metallic		●	●		●	●		●	●		●
A31 Indianapolis Red Metallic			●			●				●	●
A30 Interlagos Blue Metallic	●		●	●		●					●
475 Black Sapphire Metallic	●	●	●	●	●	●	●	●	●	●	●
Interior trim											
Brushed Aluminum Shadow⁶											
Olive Ash Wood⁷											
Walnut Madeira Wood⁷											

Please note: Due to color printer capabilities, colors shown may not print out accurately.

¹Merino Leather (Extended): Standard; includes Anthracite Cloth roofliner and side pillars.

²Perforated Merino Leather (Full) with Ventilated seat feature: Optional; requires optional M multi-function front seats with Active backrest-width adjustment.

³Full Leather includes leather-covered instrument panel, center console and door panels, and Anthracite Alcantara roofliner.

⁴Merino Leather (Full): Optional.

⁵All exterior paint colors are standard on the M5.

⁶Brushed Aluminum Shadow trim: Standard.

⁷Olive Ash Wood trim and Walnut Madeira Wood trim: No-cost options.

/// Standard and Optional Equipment

Performance and efficiency	M5
5.0-liter, 40-valve V-10 engine with M high-pressure Double-VANOS "steplessly" variable valve timing	●
10 individual throttle butterflies, electronically controlled	●
G-sensitive semi-dry-sump lubrication system	●
Oil coolant heat exchanger	●
Digital Motor Electronics (DME) with on-board diagnostics	●
Ion flow knock control	●
3-way catalytic converter with heated oxygen sensor, activated carbon filter, controlled tank purge	●
7-speed Sequential Manual Gearbox (SMG) with Drivelogic	●
Handling, ride and braking	
Dynamic Stability Control (DSC) with M Dynamic Mode (MDM)	●
All Season Traction with M Variable Differential Lock	●
Vehicle-speed-sensitive variable-assist power steering (M Servotronic) with M Driving Dynamics Control (2 settings – throttle and steering)	●
Aluminum double-pivot strut-type front suspension and 4-link integral rear suspension	●
Independent suspension with M calibration (stiffened dampers, springs and anti-roll bars; modified rear axle geometry)	●
Electronic Damper Control with Comfort, Normal and Sport programs	●
Gas-pressurized, lightweight, double-joint spring strut front axle with aluminum crossbar	●
Lightweight integral rear axle	●
4-wheel BMW M vacuum-assisted ventilated, cross-drilled anti-lock disc brakes (ABS) with compound disc brakes	●
Instrumentation and controls	
M multi-function leather-wrapped sport steering wheel with SMG paddles, M Drive function and cruise control	●
M-design instrument cluster with white-illuminated gauges, with oil temperature gauge and variable warning segment on tachometer	●
Service Interval Indicator	●
Check Control vehicle monitoring system	●
External temperature display	●
On-board computer	●
On-board navigation system (includes 8.8" screen with 16 x 9 format)	●
Head-Up Display with additional M-specific display functions, including speed, dynamic engine speed range, shift lights, etc. ¹	○
Voice Command System	●
Vehicle & Key Memory	●

● = Standard
○ = Optional

Exterior	M5
M Radial Spoke (Styling 166M) light cast-alloy wheels, 19 x 8.5 front/19 x 9.5 rear, with 255/40ZR-19 front / 285/35ZR-19 rear performance tires ²	●
Tire Pressure Monitor system	●
BMW M front spoiler; rear spoiler and apron/air diffuser	●
Wraparound body-colored bumpers with hydraulic energy absorbers and front-compressible elements	●
Xenon Adaptive Headlights with dynamic auto-leveling feature and individual illuminating rings on all 4 headlights	●
Headlight washing system	●
Side-view mirrors with electrochromic auto-dimming, power fold-up feature and automatic tilt-down of passenger's side-view mirror when vehicle is shifted into reverse gear	●
Heated side-view mirrors, windshield washer jets and door locks	●
Rain-sensing windshield wipers with Automatic headlight control	●
4 polished stainless-steel exhaust tips	●
Clear turn-signal lenses – front, side and rear	●
Rear taillight lenses with brilliant optics	●
Park Distance Control with front and rear sensors	●
Twin-chamber exhaust system with twin dual chrome-plated tailpipes	●
Choice of standard or metallic paint	●
Interior seating and trim³	
16-way power BMW M front sport seats (includes 4-way lumbar support and 2-way thigh support), and 2-way manual headrests	●
3-setting memory system for driver's seat and safety belt height, steering wheel and outside mirrors	●
M multi-function front seats with Active backrest-width adjustment	○
Merino Leather upholstery (Extended)	●
Merino Leather upholstery (Full)	○
Perforated Merino Leather upholstery (Full) with Ventilated Seats feature (requires optional M multi-function seats)	○
Brushed Aluminum Shadow interior trim	●
Olive Ash Wood ⁴	○
Walnut Madeira Wood ⁴	○
Front and rear center armrest	●
M-badged doorsills	●

¹ Not available with Green band windshield.

² Due to low-profile tires, please note: wheels, tires and suspension parts are more susceptible to road hazard and consequential damages. Performance tires not recommended for driving in ice and snow.

³ See page 14 for requirements on ordering upholstery, seats and trim.

⁴ No-cost option.

/// Standard and Optional Equipment

Audio system	M5
Logic7 Surround Sound anti-theft AM/FM stereo/CD audio system with 13 upgraded speakers (including 2 subwoofers), Digital Sound Processing (DSP), Radio Data System (RDS), Auto-Store and 3-channel FM diversity antenna	●
6-disc CD changer mounted in glove compartment; includes all features of standard audio system	●
Pre-wiring for BMW center installation of BMW 6-CD changer	●
SIRIUS Satellite Radio	○
Comfort and convenience	
Automatic climate control with separate left/right temperature and air distribution controls, with automatic air recirculation	●
Micro-filter ventilation system with replaceable active-charcoal filters	●
3-stage heated front seats	●
3-stage heated rear seats	○
Large 2-way power glass moonroof with remote, expanded "one-touch" operation, anti-trapping feature, and sliding interior sunshade	●
Power tilt and telescopic steering wheel with automatic tilt-up	●
Power windows with key-off and "one touch" up and down operation both front and rear, anti-trapping feature, opening from remote, and closing from exterior lock	●
Power rear-window sunshade and manual rear side-window sunshades with 2 shade sections per door	○
Remote control key	●
Comfort Access keyless entry with multi-function remote control	○
BMW Ambiance Lighting	●
Interior courtesy lights with automatic dimming function	●
Front map lights and rear reading lights with separate left/right controls	●
Dual front sun visors with illuminated mirrors	●
Ground-illuminating lights in door handles	●
Integrated 3-button Universal Transceiver	●
Dual cupholders in front and rear	●
Heated driver's door lock and rear window defroster	●
Split fold-down through-load rear seats and ski bag	○
Fully finished trunk with drop-down tool kit and interior trunk release	●
Power outlet in trunk, front passenger's footwell and back of center console	●
Glove compartment with rechargeable take-out flashlight	●

● = Standard
○ = Optional

Safety and security	M5
Driver's and passenger's front airbag supplemental restraint system (SRS) with "smart" dual-stage and dual-threshold deployment, and sensor to help prevent unnecessary passenger's airbag deployment	●
Front- and rear-seat Head Protection System (AHPS II)	●
Front-door-mounted side-impact airbags	●
Automatic front safety belt pretensioners and force limiters	●
Manual height adjustment for front safety belts	●
Rear-seat side-impact airbags and automatic pretensioners on rear outboard safety belts	○
Automatic-locking retractors (ALR) on all safety belts (for installation of child-restraint seats)	●
Interlocking door anchoring system to help protect against door intrusion in side impacts	●
Intelligent Safety and Information System (ISIS) for safety systems deployment	●
Impact sensor that activates Battery Safety Terminal disconnect of alternator, fuel pump and starter from battery; turns on hazard lights, interior lights and unlocks doors	●
Coded Driveaway Protection (prevents engine start when your key, with constantly changing electronic code, is not used)	●
Remote keyless entry security alarm system with selective unlocking and double-lock features (programmed at BMW center), remote trunk opening, interior motion detector, and panic feature	●
Adaptive Brake Lights	●
BMW Assist with Bluetooth® wireless technology	●
BMW Maintenance Program	
BMW Full Maintenance ⁵	●

⁵ Full Maintenance Program covers all factory-recommended maintenance, as determined by the Service Interval Indicator for 4 years or 50,000 miles, whichever comes first. Full Maintenance Program includes items that need replacement due to normal wear and tear, provided wear and tear exceeds BMW specifications. This includes items such as brake pads, brake rotors and wiper blades that are not covered by the original New Vehicle Limited Warranty. Any adjustments required due to normal operating conditions are also included. For exclusions and limitations, refer to the Service and Warranty Information booklet that came with the BMW.

/// Stand-alone Options

Code	Item
261	Rear side airbags and automatic pretensioners on rear outboard safety belts
322	Comfort Access keyless entry with multi-function remote control
416	Power rear-window sunshade and manual rear side-window sunshades with 2 shade sections per door
453	Ventilated front seats, requires Perforated Merino Leather (Full) and M multi-function front seats (4MA)
465	Split fold-down through-load rear seats and ski bag
496	3-stage heated rear seats
610	Head-up Display with additional M-specific display functions, including speed, dynamic engine speed range, shift lights, etc. ¹
655	SIRIUS Satellite Radio
4MA	M multi-function front seats with Active backrest-width adjustment ²
4ME	Walnut Madeira Wood interior trim ^{2,4}
4MK	Olive Ash Wood interior trim ^{2,4}
ZSD	Rear spoiler deletion

¹ Not available with Green band windshield.

² See page 14 for requirements on ordering upholstery, seats and trim.

³ No-cost option.



/// Technical Data / Specifications

Weight		M5
Unladen	lbs	4012
Weight distribution, front/rear	%	52.2/47.8
Engine		
Liters/cylinders/valves per cylinder		5.0/V-10/4
Displacement	cu cm	4999
Bore/Stroke	in	3.62/2.96
Nominal output/rpm	hp	500/7750
Max torque/rpm	lb-ft	383/6100
Compression ratio	:1	12.0
Transmission		
SMG gear ratios		
I/II/III	:1	3.99/2.65/1.81
IV/V/VI	:1	1.39/1.16/1.00
VII/R	:1	0.83/3.99
Final drive ratio	:1	3.62

Performance		M5
Drag coefficient	C _d	0.31
Top speed ¹	mph	155
Acceleration 0 - 60 mph ²	sec	4.5
Fuel consumption³		
7-speed SMG transmission		
City	mpg	TBD
Highway	mpg	TBD
Tires and Wheels		
Tire dimensions (performance tires) ⁴	front	255/40ZR-19
	rear	285/35ZR-19
Wheel dimensions, front/rear		19 x 8.5/19 x 9.5
Material		Light cast-alloy

¹ Top speed limited electronically.

² BMW AG test results. Actual acceleration results may vary, depending on specification of vehicle; road and environmental conditions; testing procedures and driving style. These results should be used for comparison only and verification should not be attempted on public roads. **BMW urges you to obey all posted speed laws and always wear safety belts.**

³ EPA-estimated figures are for comparison purposes only. Your actual mileage will vary, depending on speed, driving habits, trip length and driving conditions; actual mileage will most likely be lower.

⁴ Due to low-profile tires, please note: wheels, tires and suspension parts are more susceptible to road hazard and consequential damages. Performance tires not recommended for driving in ice and snow.



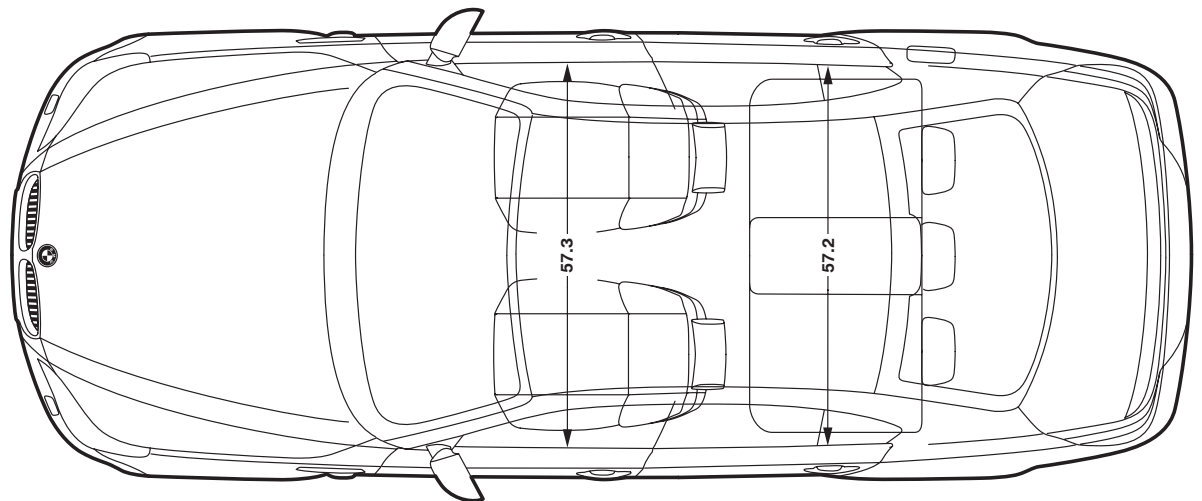
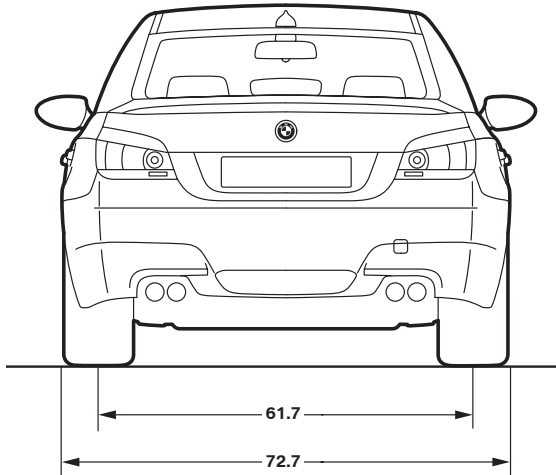
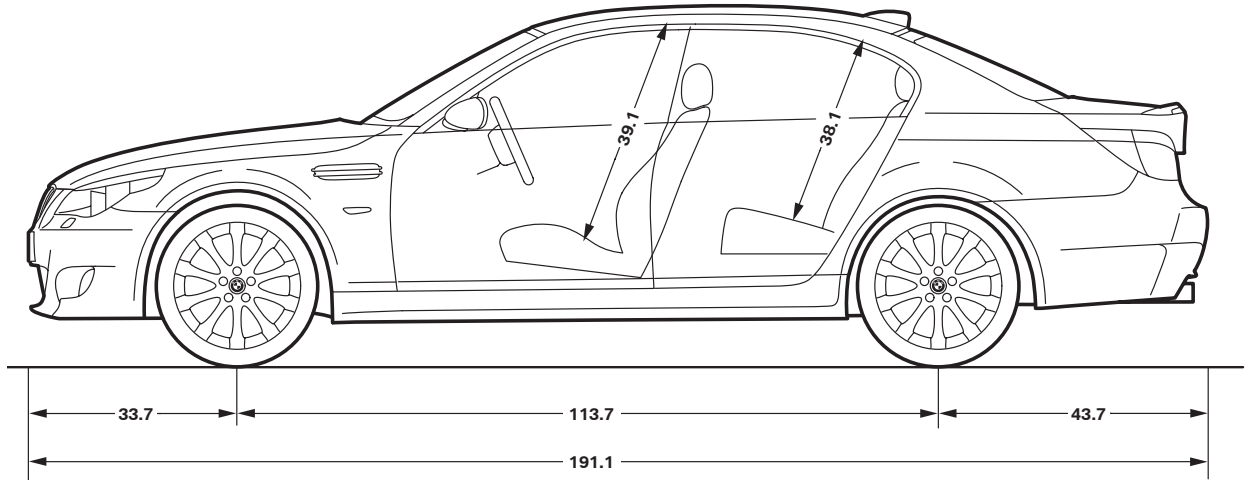
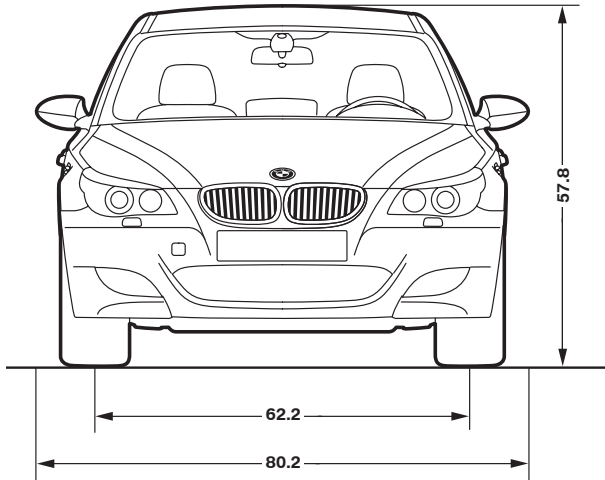

More about BMW



bmwusa.com
1-800-334-4BMW

The Ultimate
Driving Machine®



U.S. Importer: BMW of North America, LLC, Woodcliff Lake, NJ 07677. All illustrations and specifications contained in this brochure are based on the latest product information available at the time of printing. BMW reserves the right to make changes at any time, without notice, in colors, materials, equipment, specifications and models. BMW may, subject to legal requirements, determine the Model Year designation of its vehicles. The Model Year designation on any particular model may be longer or shorter than 12 months. Some vehicles pictured may contain non-U.S. equipment. Some models may be shown with optional equipment. Due to low-profile tires, please note: wheels, tires and suspension parts are more susceptible to road hazard and consequential damages. While BMW NA makes all diligent efforts to provide accurate information in this brochure, there is no guarantee or warranty of accuracy. Furthermore, we do not assume any liability for the accuracy or completeness of information presented. This brochure shall not be used or relied upon as a substitute for information that is available from your BMW center. Further information can be obtained from your authorized BMW center or bmwusa.com. ©2005 BMW of North America, LLC. Not to be reproduced wholly or in part without written permission from BMW of North America. The BMW name and logo are registered trademarks. The Bluetooth word mark and logos are owned by the Bluetooth SIG, Inc. and use of such marks by BMW is under license. Other trademarks and trade names are those of their respective owners.

European model shown.

CN1015568